



Air-Powered Gearmotors

1AM and 1UP Series, 15:1 reduction, 10 – 95 lbs. in. (1 – 11 Nm) torque at 40 rpm (minimum speed reduction)

MODEL

1AM-NRV-56-GR11

(4 Vanes, Reversible)

1AM-NRV-60-GR11

(8 Vanes, Reversible)

Net wt. 5 lbs. (2,3 kg)

FEATURES

- 15:1 gear reducer
- Face mounting
- Horizontal or shaft down operation
- Muffler AF350 (shown in photo)

RECOMMENDED

- Filter AH100F
- Regulator AH101R
- Gauge AA807
- Lubricator AH102L
- Oil AD220 – 1 quart (.94 litres)
- Repair kit K278 (Air motor only, 8 Vane)
- Repair kit K201 (Air motor only, 4 Vane)

OPTIONAL

- Muffler AL444 (for additional noise reduction) see pages 6, 8

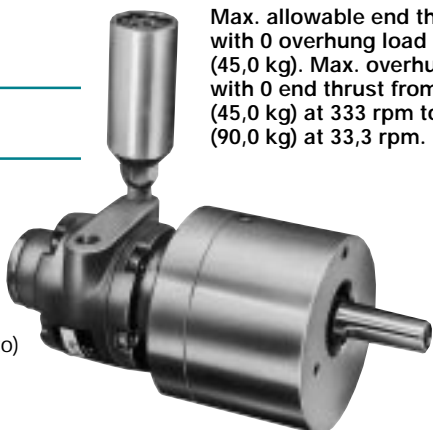

Max. allowable end thrust with 0 overhung load is 100 lbs. (45,0 kg). Max. overhung load with 0 end thrust from 100 lbs. (45,0 kg) at 333 rpm to 200 lbs. (90,0 kg) at 33,3 rpm.

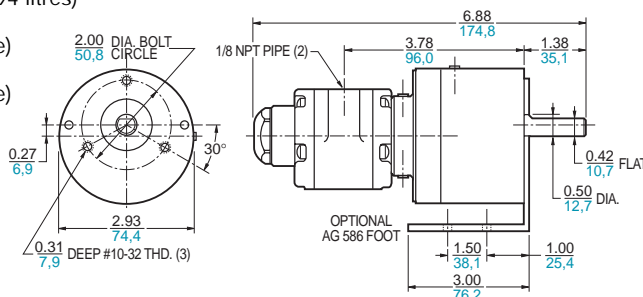

Output Power vs. Speed

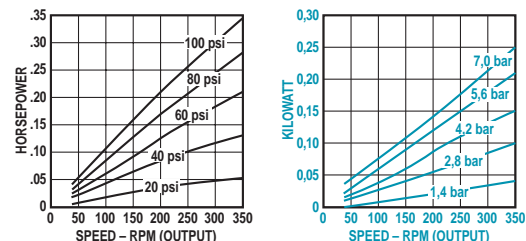

Torque vs. Speed

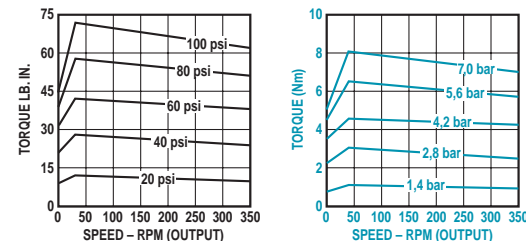

Air Consumption vs. Speed

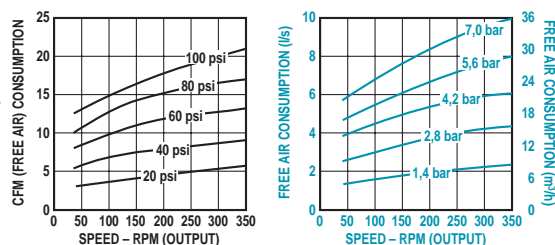

MODEL

1UP-NRV-4-GR11

(4 Vanes, Reversible)

1UP-NRV-11-GR11

(8 Vanes, Reversible)

Net wt. 5 lbs. (2,3 kg)

FEATURES

- 15:1 gear reducer
- Face mounting
- Horizontal or shaft down operation
- Muffler AF350 (shown in photo)

RECOMMENDED

- Filter AH100F
- Regulator AH101R
- Gauge AA807
- Lubricator AH102L
- Oil AD220 – 1 quart (.94 litres)
- Repair kit K298 (Air motor only, 8 Vane)
- Repair kit K286 (Air motor only, 4 Vane)

OPTIONAL

- Muffler AL444 (for additional noise reduction) see pages 6, 8

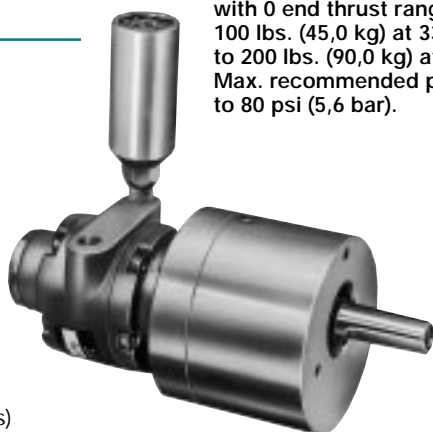

Max. allowable end thrust with 0 overhung load is 100 lbs. (45,0 kg). Max. overhung load with 0 end thrust ranges from 100 lbs. (45,0 kg) at 333 rpm to 200 lbs. (90,0 kg) at 33,3 rpm. Max. recommended pressures to 80 psi (5,6 bar).

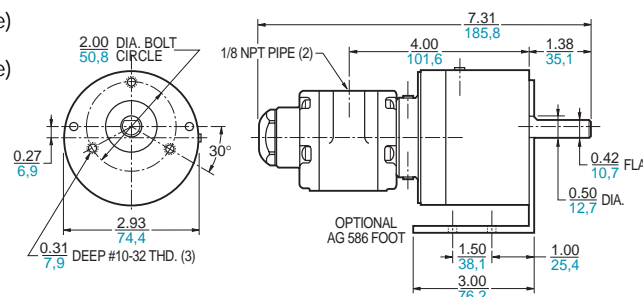

Output Power vs. Speed

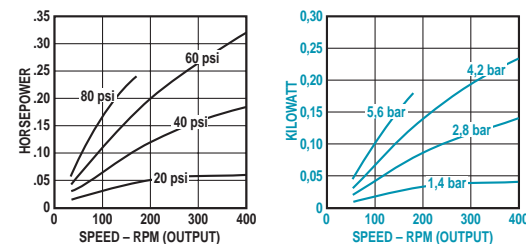

Torque vs. Speed

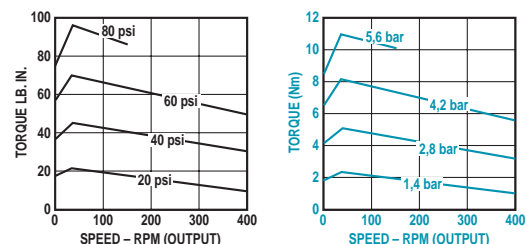

Air Consumption vs. Speed

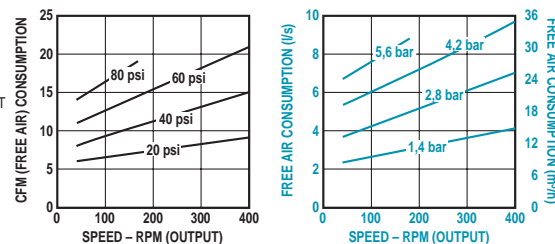

■ = METRIC (mm) ■ = IMPERIAL (inches)