



Air Motors up to 1/2 hp, speeds from 500 to 10,000 rpm, max. pressure 100 psi (7 bar)



MODEL

1AM-NCC-12

(4 Vanes, CCW Rotation)

1AM-NCW-14

(4 Vanes, CW Rotation)

1AM-NRV-39A

(4 Vanes, Reversible)

1AM-NRV-63A

(8 Vanes, Reversible)

Net wt. 2 lbs. (0,9 kg)

FEATURES

- Hub mounting
- Any plane operation
- Muffler AF350

RECOMMENDED

- Filter AH100F
- Regulator AH101R
- Gauge AA807
- Lubricator AH102L
- Oil AD220 – 1 quart (.94 litres)
- Repair kit K200 (Single Rotation)
- Repair kit K201 (Reversible)
- Repair kit K278 (8 Vane, Reversible)

OPTIONAL

- Foot mounting (see page 27)
- Muffler AL444 (for additional noise reduction) see page 6

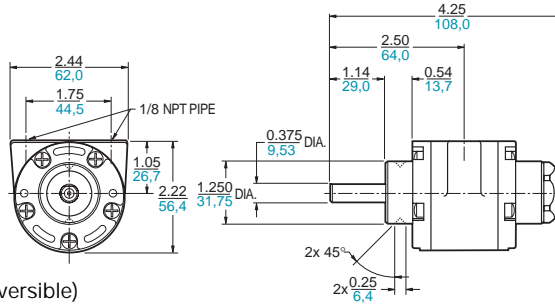

Output Power vs. Speed

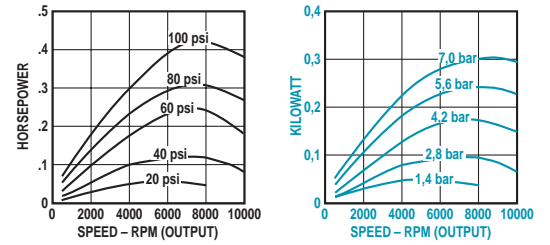

Torque vs. Speed

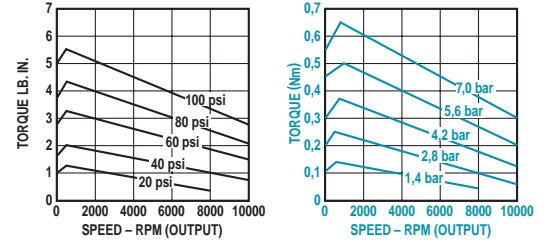

Air Consumption vs. Speed

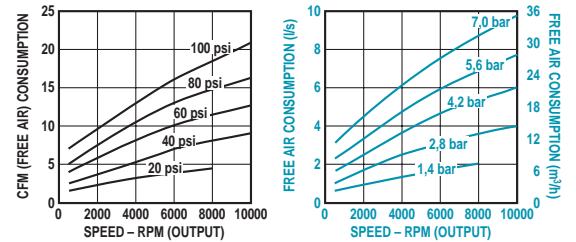

1UP-NCC-1A

(4 Vanes, CCW Rotation)

1UP-NCW-2A

(4 Vanes, CW Rotation)

1UP-NRV-3A

(4 Vanes, Reversible)

1UP-NRV-10

(8 Vanes, Reversible)

Net wt. 3 lbs. (1,4 kg)

FEATURES

- Hub mounting
- Any plane operation
- Muffler AF350

RECOMMENDED

- Filter AH100F
- Regulator AH101R
- Gauge AA807
- Lubricator AH102L
- Oil AD220 – 1 quart (.94 litres)
- Repair kit K285 (Single Rotation)
- Repair kit K286 (Reversible)
- Repair kit K298 (8 Vane, Reversible)

OPTIONAL

- Foot mounting (see page 27)
- Muffler AL444 (for additional noise reduction) see page 6

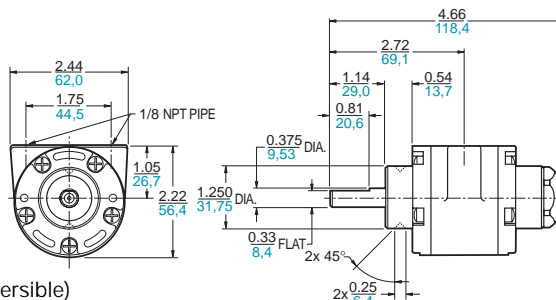

Output Power vs. Speed

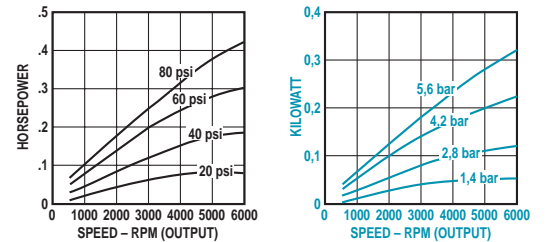

Torque vs. Speed

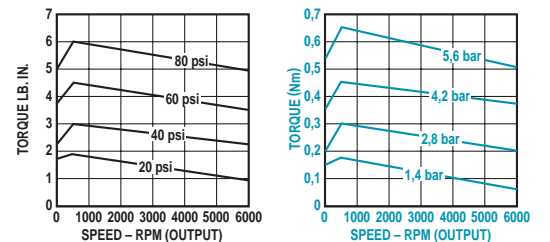

Air Consumption vs. Speed

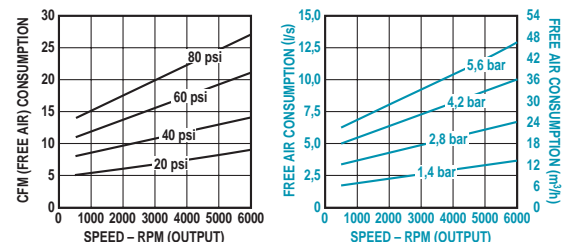

■ = METRIC (mm) ■ = IMPERIAL (inches)