



Air Motors up to 4 hp, speeds from 300 to 3,000 rpm, max. pressure 100 psi (7 bar)

MODEL

6AM-FRV-5A (4 Vanes, Reversible)

6AM-FRV-23A (8 Vanes, Reversible)

Net wt. 21 lbs. (9,5 kg)

FEATURES

- Foot mounting
- Any plane operation
- Muffler AC990

RECOMMENDED

- Filter AH106F
- Regulator AH107R
- Gauge AA806
- Lubricator AH108L
- Oil AD220 – 1 quart (.94 litres)
- Repair kit K208 (4 Vane)
- Repair kit K281 (8 Vane)

OPTIONAL

- Muffler AL476 (for additional noise reduction) see pages 6, 8

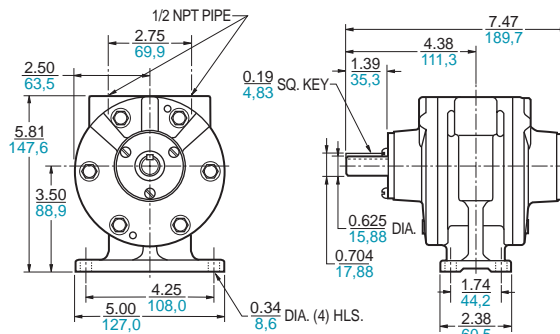

6AM-NRV-7A (4 Vanes, Reversible)

Net wt. 18 lbs. (8,1 kg)

FEATURES

- Face mounting
- Any plane operation
- Muffler AC990

RECOMMENDED

- Filter AH106F
- Regulator AH107R
- Gauge AA806
- Lubricator AH108L
- Oil AD220 – 1 quart (.94 litres)
- Repair kit K208

OPTIONAL

- Muffler AL476 (for additional noise reduction) see pages 6, 8

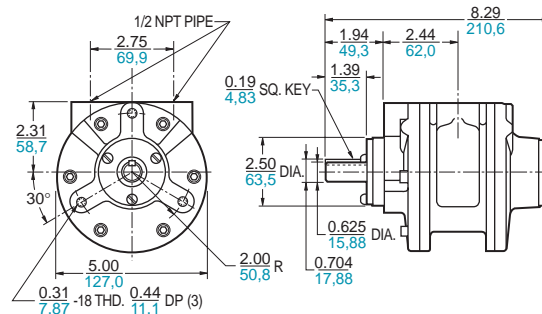

6AM-NRV-11A (4 Vanes, Reversible)

6AM-NRV-22A (8 Vanes, Reversible)

Net wt. 24 lbs. (10,8 kg)

FEATURES

- NEMA 56C mounting
- Any plane operation
- Muffler AC990

RECOMMENDED

- Filter AH106F
- Regulator AH107R
- Gauge AA806
- Lubricator AH108L
- Oil AD220 – 1 quart (.94 litres)
- Repair kit K208 (4 Vane)
- Repair kit K281 (8 Vane)

OPTIONAL

- Muffler AL476 (for additional noise reduction) see pages 6, 8

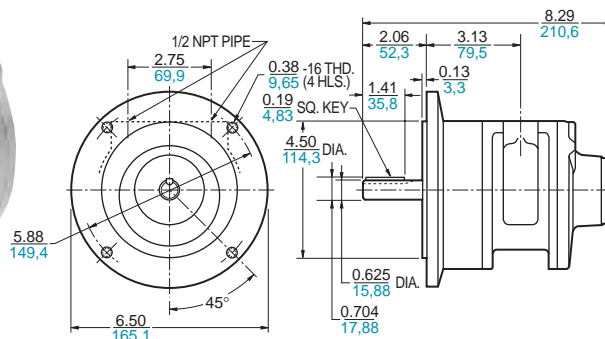



Metric Models



MODEL

6AM-ARV-54

(4 Vanes, Reversible)
Repair kit K281A

6AM-ARV-55

(8 Vanes, Reversible)
Repair kit K281B

FEATURES

- IEC #72 mounting frame size D80
- Any plane operation
- Muffler AC990 (photo)

OPTIONAL

- Muffler AL476 (for additional noise reduction) see pages 6, 8

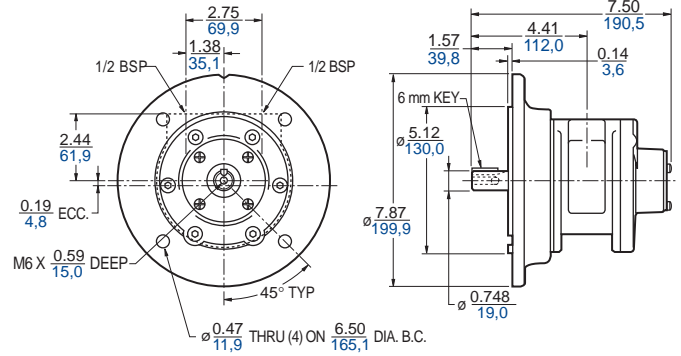

Delivers up to 3 kW (4 hp). Speeds may be varied from 300 to 3,000 rpm. Max. recommended operating pressure 7 bar (100 psi).

Note: Performance data represents a 4-vane model with no exhaust restriction.

Output Power vs. Speed

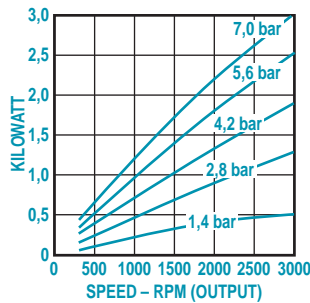
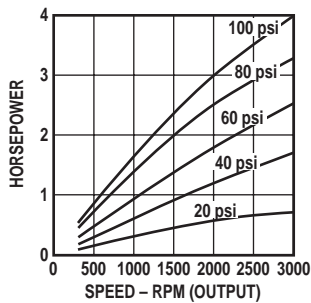

Torque vs. Speed

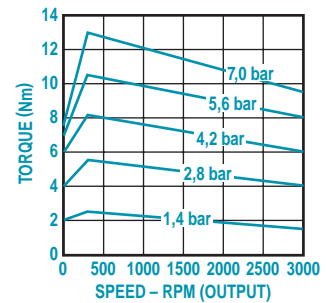
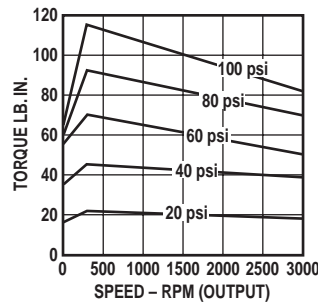

Air Consumption vs. Speed

