



Air Motors up to 5 hp, speeds from 300 to 2,500 rpm, max. pressure 100 psi (7 bar)

MODEL

8AM-FRV-2B (4 Vanes, Reversible)

8AM-FRV-30A (8 Vanes, Reversible)

Net wt. 27 lbs. (12,2 kg)

FEATURES

- Foot mounting
- Any plane operation
- Muffler AC990

RECOMMENDED

- Filter AH106F
- Regulator AH107R
- Gauge AA806
- Lubricator AH108L
- Muffler AG600 – above 1,000 rpm
- Oil AD220 – 1 quart (.94 litres)
- Repair kit K210 (4 Vane)
- Repair kit K283 (8 Vane)

OPTIONAL

- Muffler AL476 (for additional noise reduction) see pages 6, 8

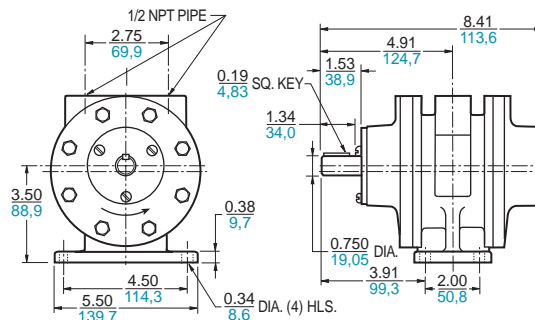
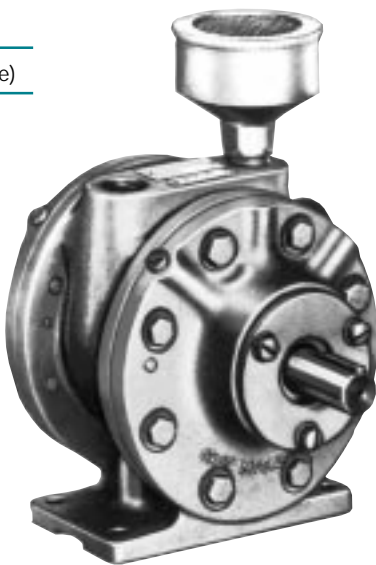

8AM-NRV-5B (4 Vanes, Reversible)

8AM-NRV-42A (8 Vanes, Reversible)

Net wt. 28 lbs. (12,6 kg)

FEATURES

- Face mounting
- Any plane operation
- Muffler AC990

RECOMMENDED

- Filter AH106F
- Regulator AH107R
- Gauge AA806
- Lubricator AH108L
- Muffler AG600 – above 1,000 rpm
- Oil AD220 – 1 quart (.94 litres)
- Repair kit K210 (4 Vane)
- Repair kit K283 (8 Vane)

OPTIONAL

- Muffler AL476 (for additional noise reduction) see pages 6, 8

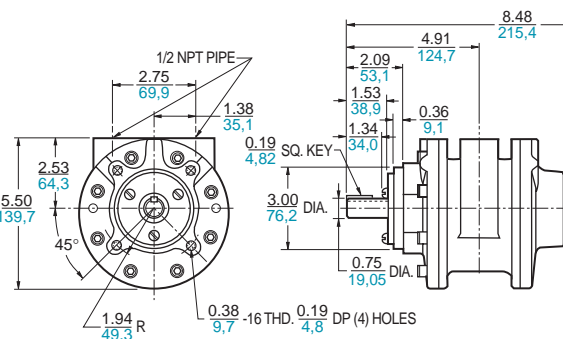

8AM-NRV-28A (4 Vanes, Reversible)

8AM-NRV-32A (8 Vanes, Reversible)

Net wt. 28 lbs. (12,6 kg)

FEATURES

- NEMA 145TC mounting
- Any plane operation
- Muffler AC990

RECOMMENDED

- Filter AH106F
- Regulator AH107R
- Gauge AA806
- Lubricator AH108L
- Muffler AG600 – above 1,000 rpm
- Oil AD220 – 1 quart (.94 litres)
- Repair kit K211 (4 Vane)
- Repair kit K282 (8 Vane)

OPTIONAL

- Muffler AL476 (for additional noise reduction) see pages 6, 8

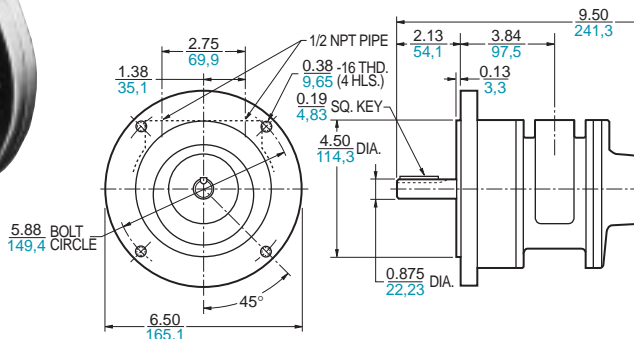



Metric Models



MODEL

8AM-ARV-70

(4 Vanes, Reversible)
Repair kit K282A

8AM-ARV-71

(8 Vanes, Reversible)
Repair kit K282B

FEATURES

- IEC #72 mounting frame size D90
- Any plane operation
- Muffler AC990 (photo)

OPTIONAL

- Muffler AL476 (for additional noise reduction) see pages 6, 8

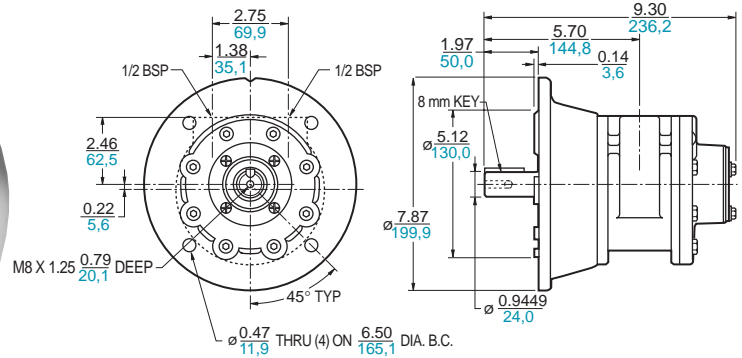

Delivers up to 3,7 kW (5 hp). Speeds may be varied from 300 to 2,500 rpm. Max. recommended operating pressure 7 bar (100 psi).

Note: Performance data represents a 4-vane model with no exhaust restriction.

Output Power vs. Speed

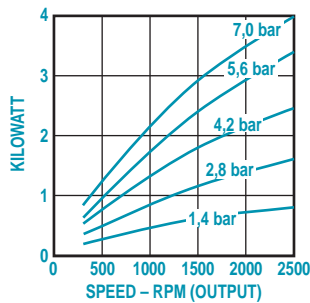
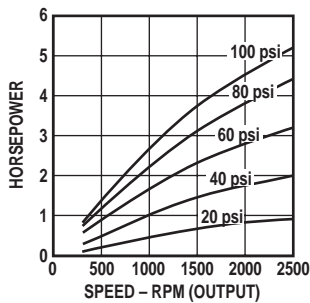

Torque vs. Speed

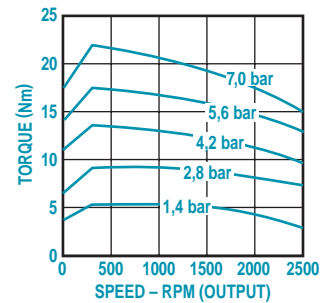
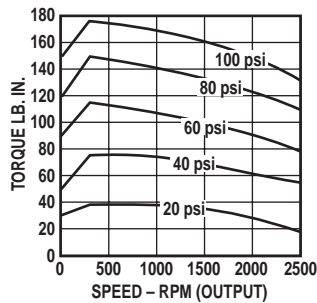

Air Consumption vs. Speed

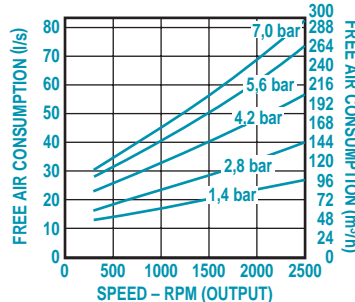
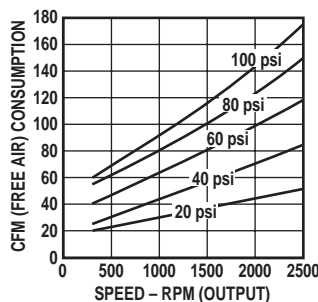

■ = METRIC (mm) ■ = IMPERIAL (inches)

®Registered Trademark/™ Trademark of Gast Manufacturing Inc. Copyright © 1999 Gast Manufacturing Inc. All rights reserved.