



Oilless Rocking Piston 1.6, 2.0, 2.4 cfm



71R/72R Series Single Cylinder Compressor

MODEL 71R135

100 PSI MAX. PRESSURE, 1.6 CFM OPEN FLOW

MODEL 71R142

100 PSI MAX. PRESSURE, 2.0 CFM OPEN FLOW

MODEL 72R142

50 PSI MAX. PRESSURE, 2.4 CFM OPEN FLOW

(mm) (inches)

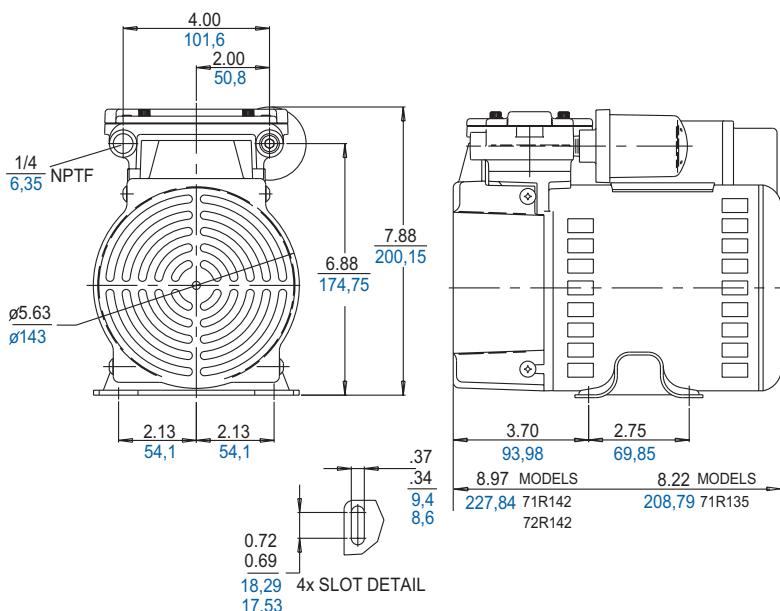

PRODUCT FEATURES

- Oilless operation
- All wetted aluminum parts treated for corrosion protection from moisture
- Rugged motor shell construction

INCLUDES

- Filter B300F

COMMON MOTOR OPTIONS

- 100/100-115V, 50/60 Hz, single phase
- 200/240V, 50/60 Hz, single phase

RECOMMENDED ACCESSORIES

- Relief valve AF592S
- Pressure gauge AF583

Product Specifications

Model Number	Motor	Type	RPM		HP	kw	Net Wt.	
			60 Cycle	50 Cycle			lbs.	kg
71R135-P001B-D200X	100-100-115-50/60-1	PSC (4 Pole)	1675	1400	1/4	0,19	14	6,4
71R142-P001B-D300X	100/100-115-50/60-1	PSC (4 Pole)	1675	1400	1/3	0,25	14	6,4
71R142-P001B-D301X	200/240-50/60-1	PSC (4 Pole)	1675	1400	1/3	0,25	14	6,4
72R142-P001B-D300X	100/100-115-50/60-1	PSC (4 Pole)	1675	1400	1/3	0,25	14	6,4
72R142-P001B-D301X	200/240-50/60-1	PSC (4 Pole)	1675	1400	1/3	0,25	14	6,4

Product Performance (Metric, U.S.)

